



# I-35 CAPITAL EXPRESS

Marisabel Ramthun, P.E.

Director Transportation Planning and Development



# Regional Transportation System

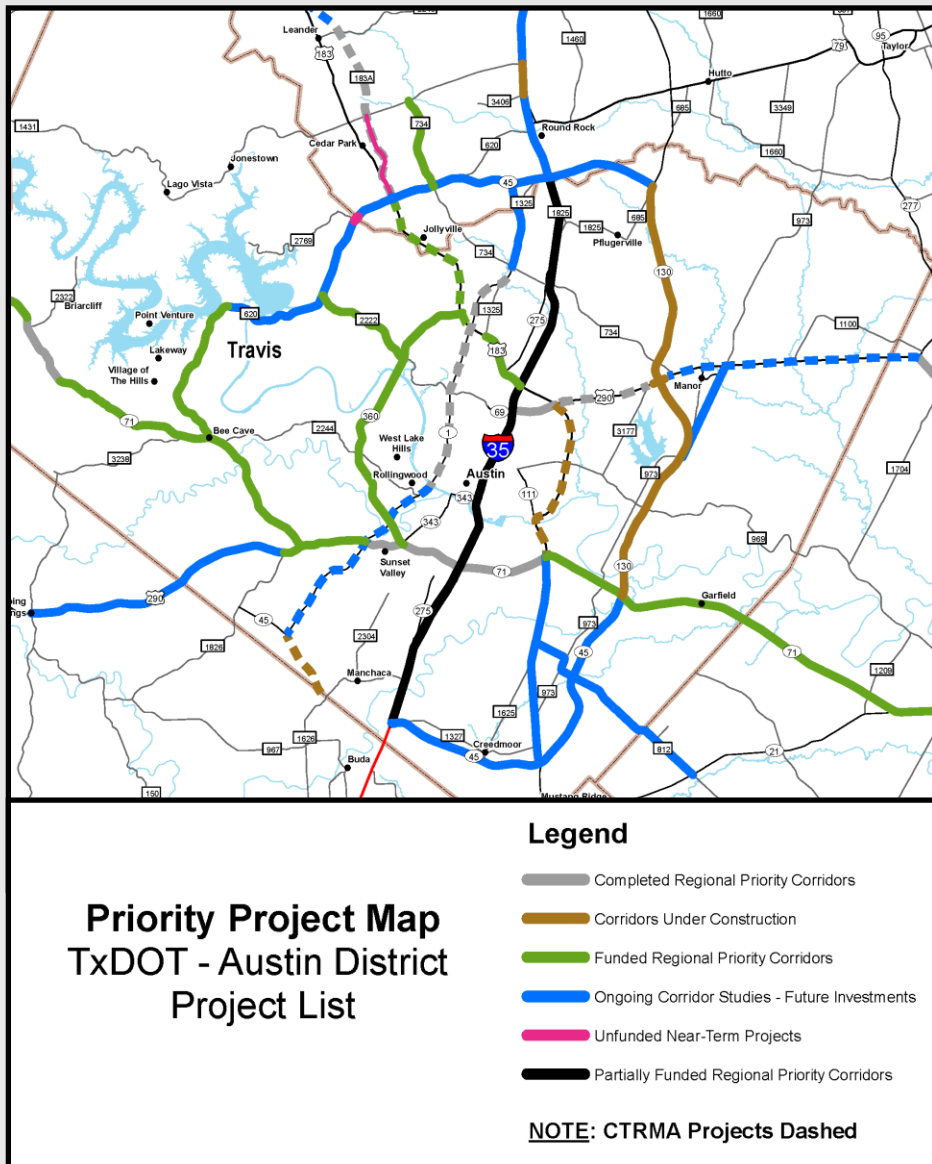

- Current Regional Funding Commitment
  - \$3.3 Billion on funded corridors and projects under construction

# Mobility35 Program – Capital Express Project



- I-35 in the Capital Area includes four Top 100 Most Congested Roadways in Texas
  - #3 – US 290E to US 290W/SH 71
  - #19 – US 290W/SH 71 to Slaughter Lane
  - #36 – Parmer Lane to US 290E
  - #78 – Slaughter Lane to SH 45SE
- I-35 is top priority in CAMPO Region
- Since 2011, TxDOT and local stakeholders have been advancing 30+ Mobility35 projects
- Capital Express completes I-35 safety and mobility improvements from SH 45N to SH 45SE
  - One to two non-tolled managed lanes each direction
  - Extensive safety and operational improvements



# I-35 Capital Area Construction Sequence

AUSTIN DISTRICT



## I-35 CAPITAL AREA CONSTRUCTION SEQUENCE PLANNING

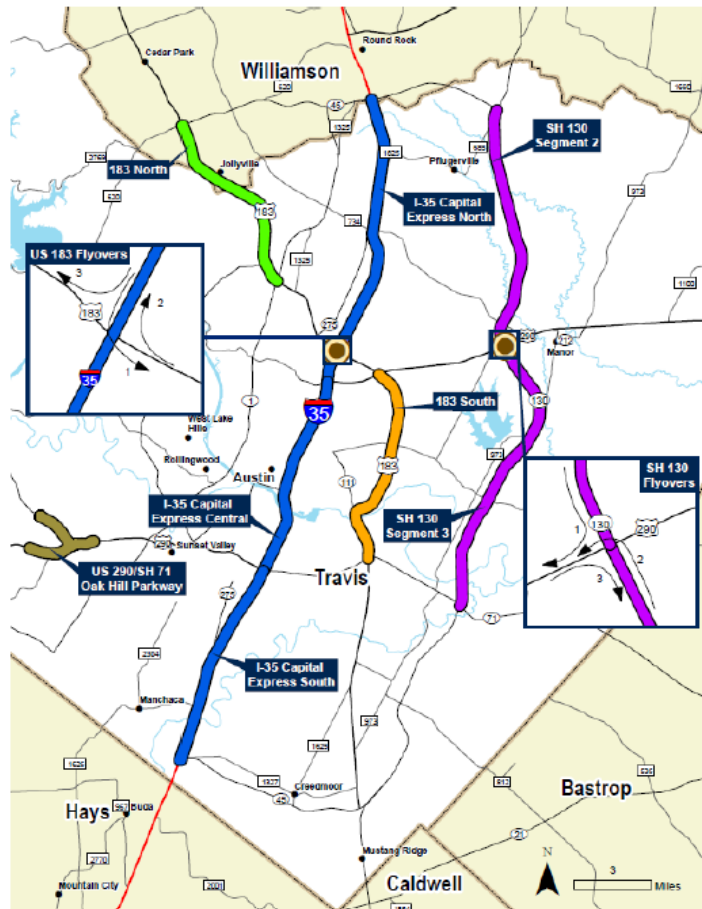

PHASING DIAGRAM

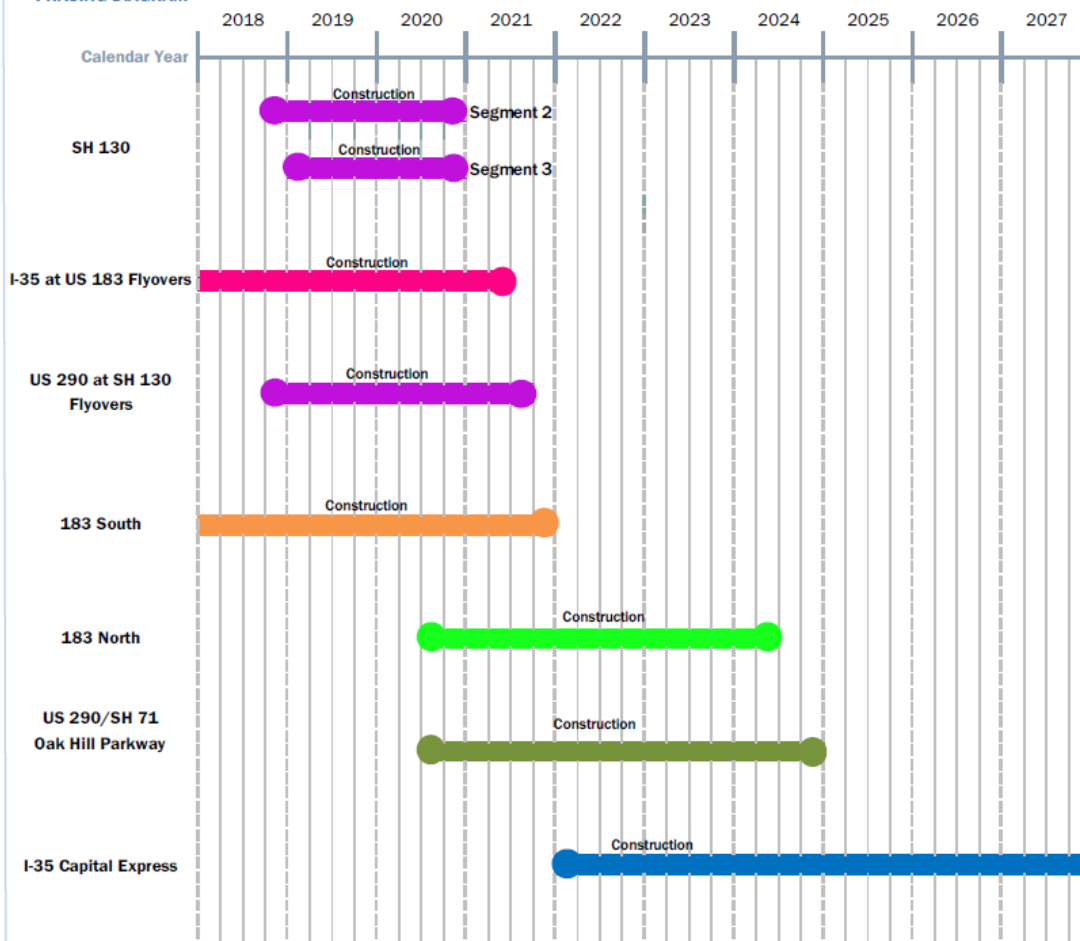

Austin District Office  
7901 N I-35  
Austin, TX 78753



CONTACT INFORMATION  
Public Information Office  
(512) 832-7000 info@mobility35.org  
Website: [www.My35.org/Capital](http://www.My35.org/Capital)

Texas Department of Transportation

Revised 05/06/2019  
Spring 2019

# Capital Express – Typical Section Overview

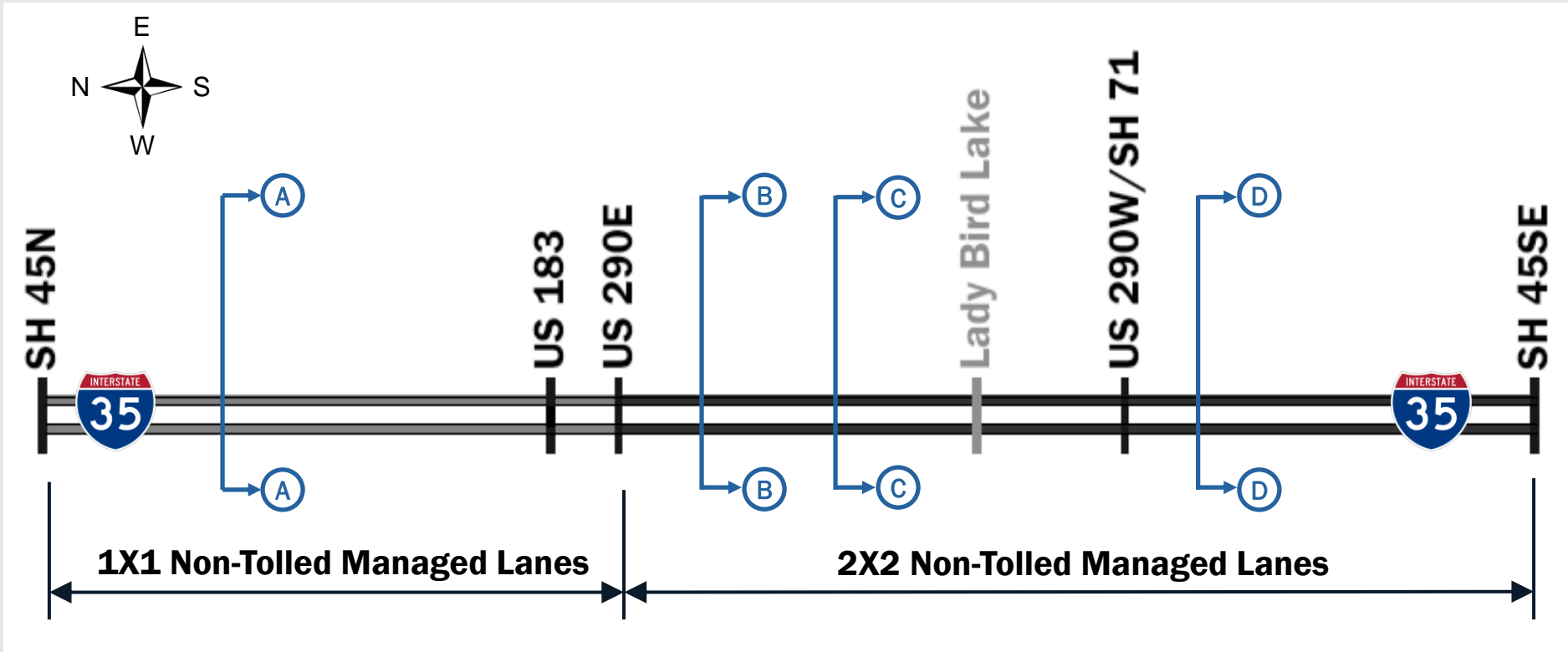

**Under Study**

# Capital Express – Typical Sections

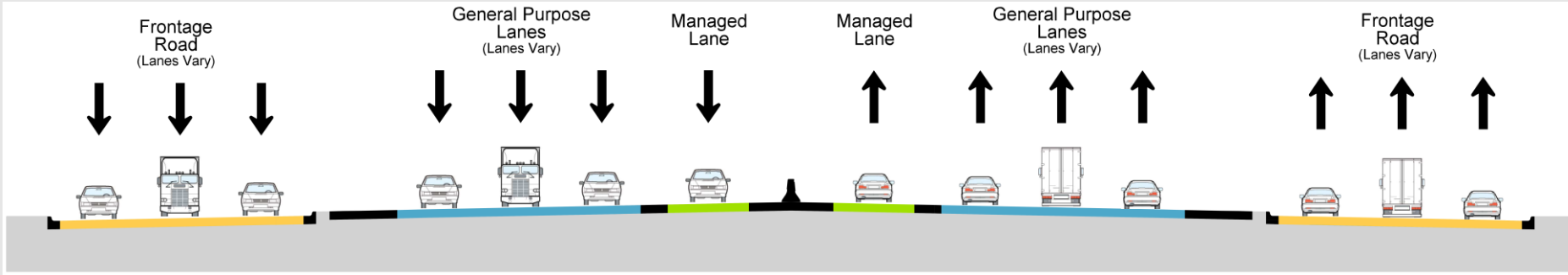

Proposed Section **A** — **A**  
SH 45N to US 290E

**Under Study**

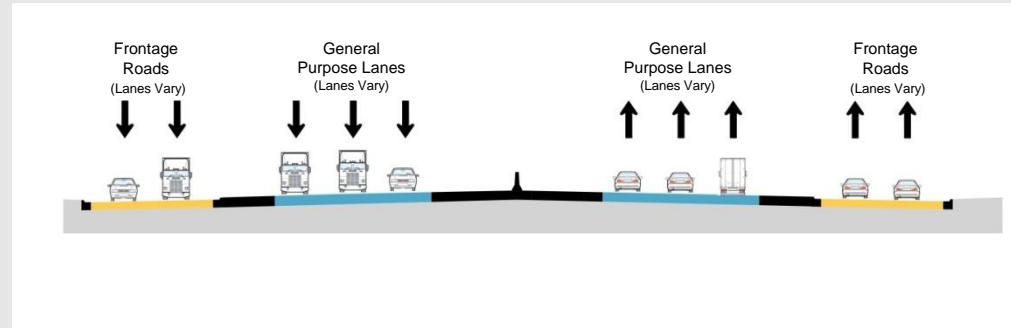
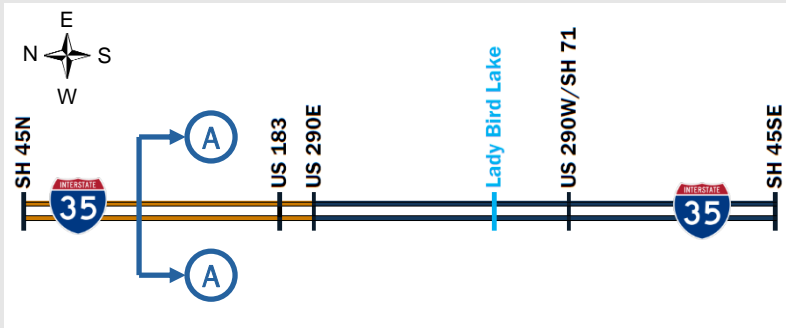

Existing I-35

# Capital Express – Typical Sections

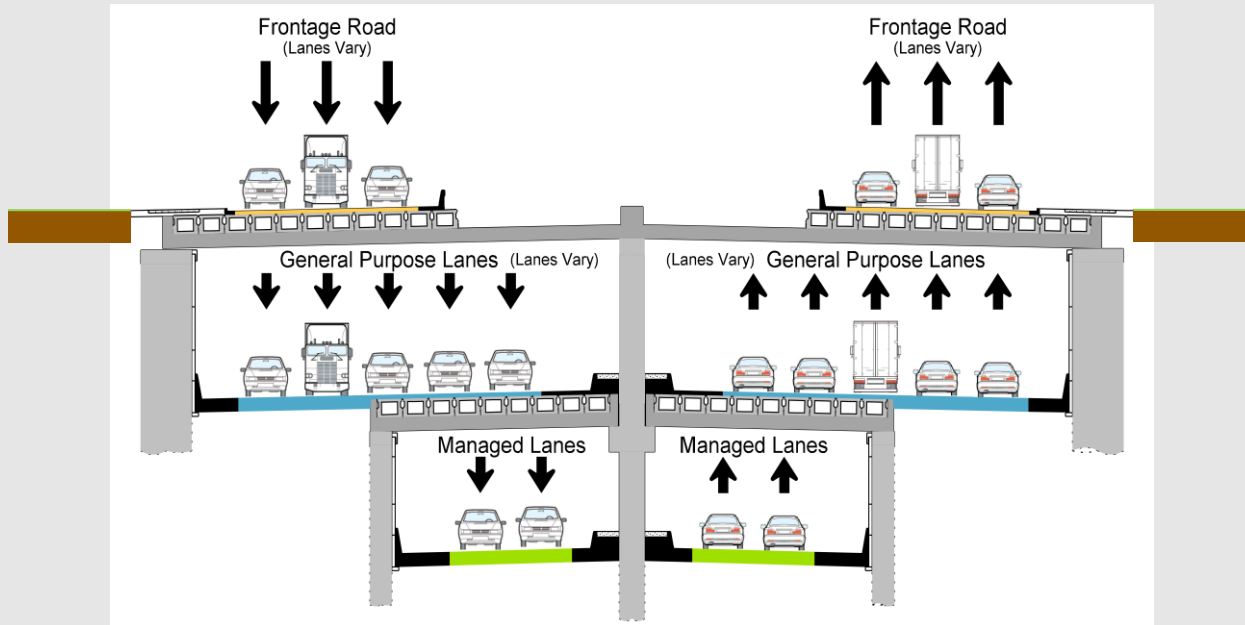

**Under Study**

**Proposed Section (B)-(B)**  
**Airport Blvd. to MLK Blvd.**

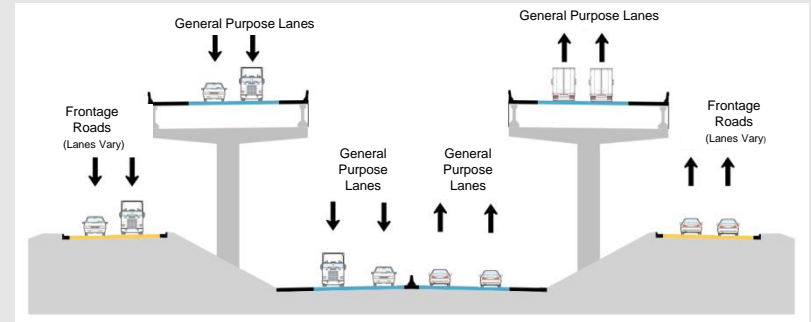
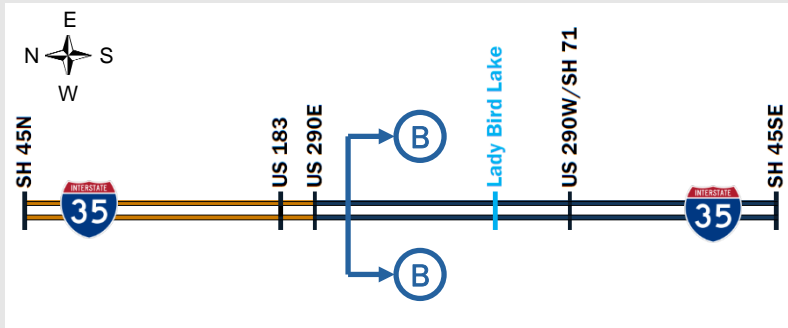

**Existing I-35**

# Capital Express – Typical Sections

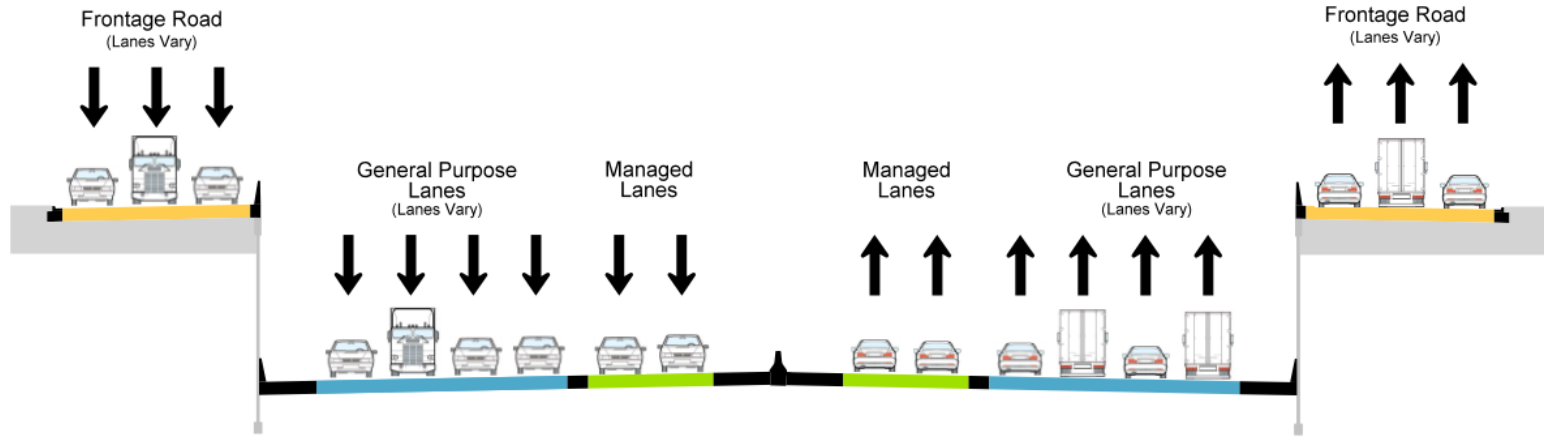

**Proposed Section**   
**MLK Blvd. to Cesar Chavez St.**

**Under Study**

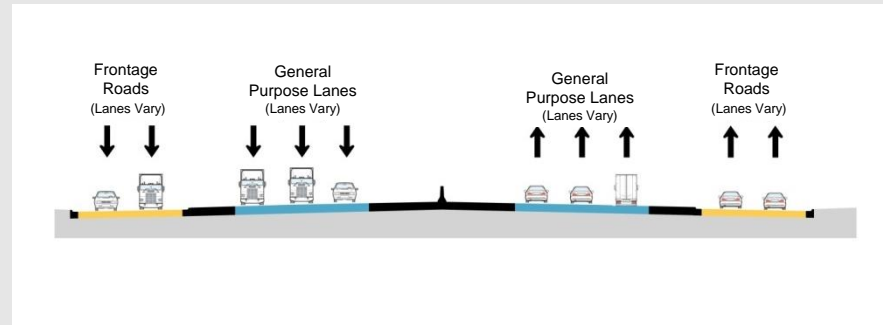
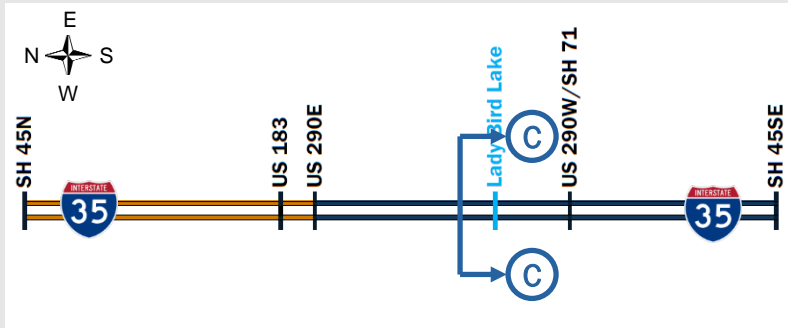

**Existing I-35**



# Capital Express – Typical Sections

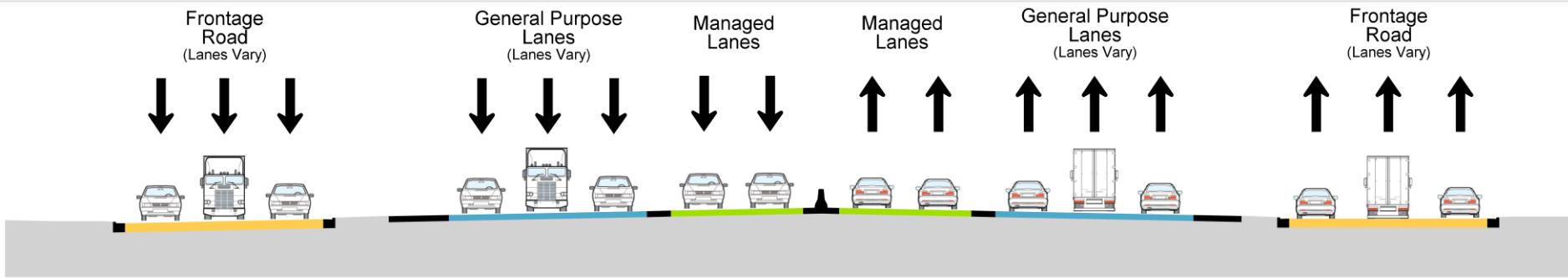

## Proposed Section Oltorf Rd. to SH 45SE

**Under Study**

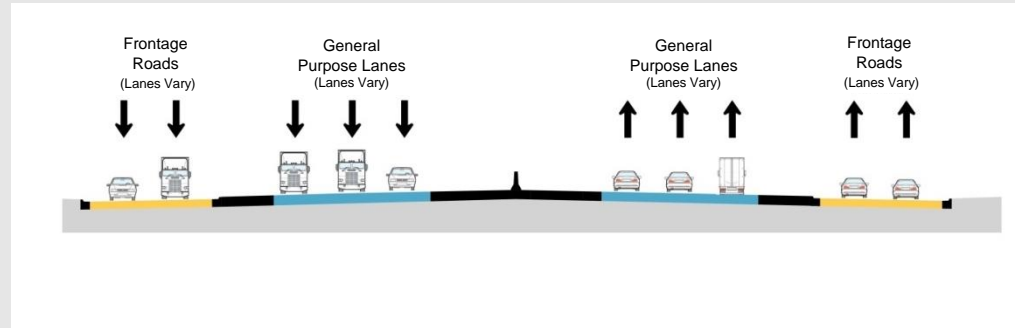
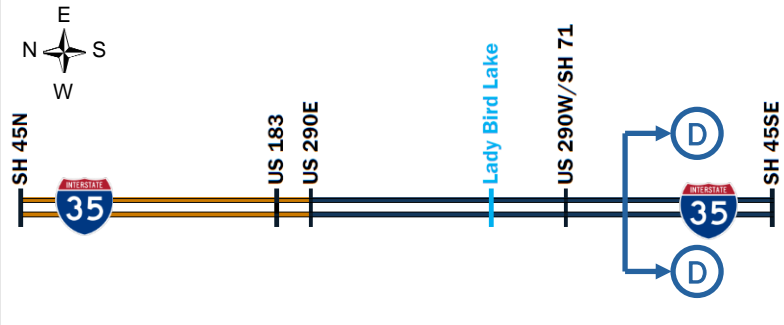

Existing I-35

# Mobility35 Capital Express Drive-through Video

- [Video](#)



# Funding Recommendation

- **Capital Express (SH 45N to SH 45SE) project**
  - Construction cost: approximately \$5.6B
  - Recommend Category 2 at \$346.59M and Category 7 at \$53.41M for a total of \$400M
- **183A Frontage Roads project** – recommend Category 7 at \$75M
- **RM 620 at Anderson Mill Road project** – recommend Category 7 at \$25M